

LOC		DIST		REVISONS			
P	LTR	DESCRIPTION	DATE	DWN	APVD		
H		REVISED PER ECO-08-004952	9JUN2008	ZMR	SLB		

EJECTION LATCHES OMITTED IN THIS VIEW FOR CLARITY

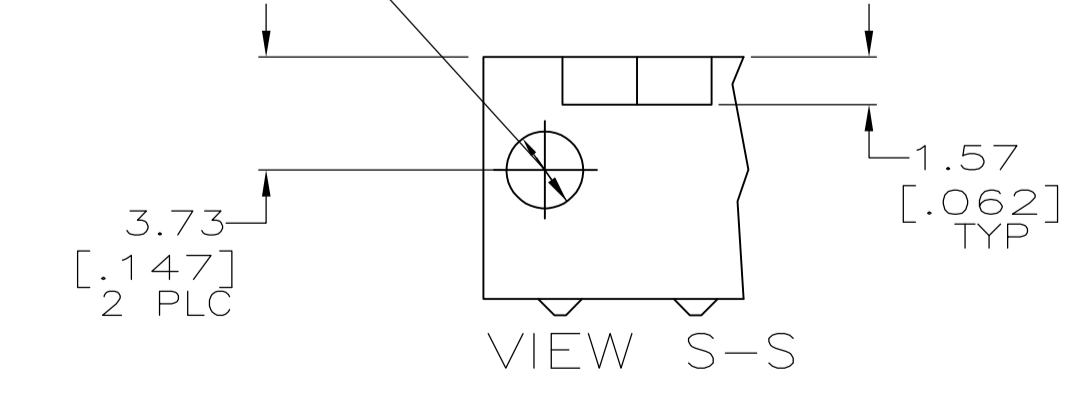
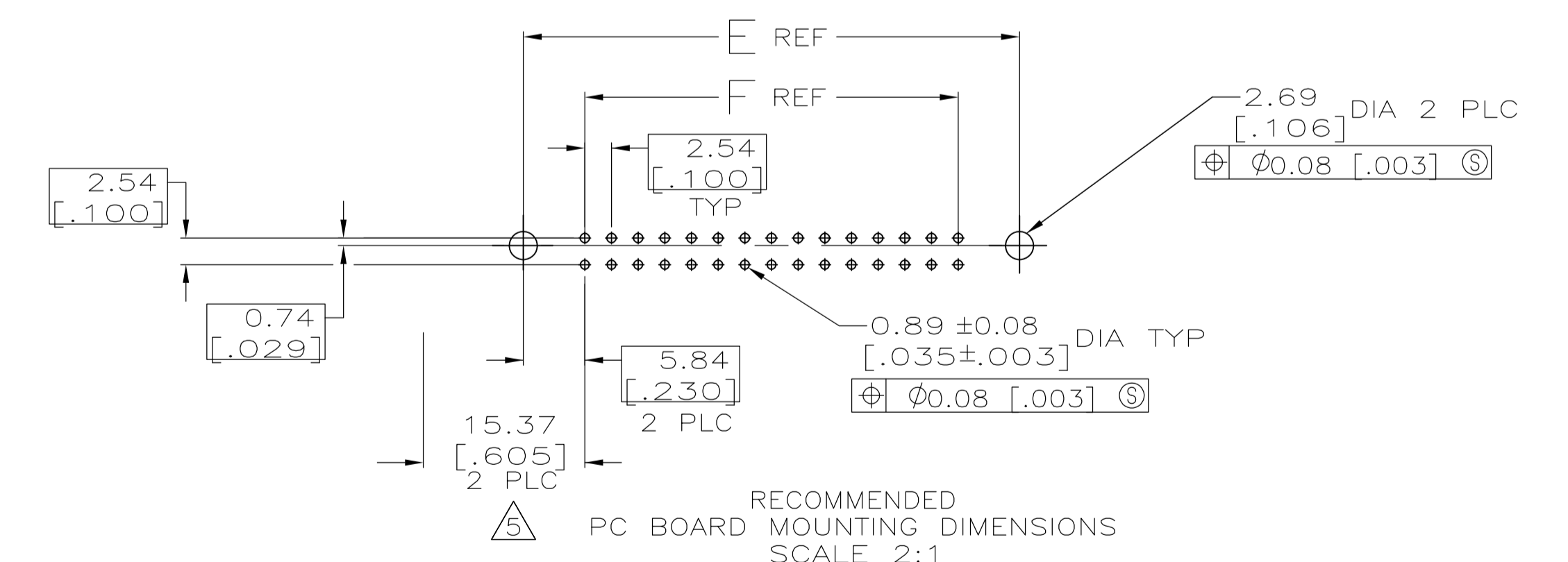
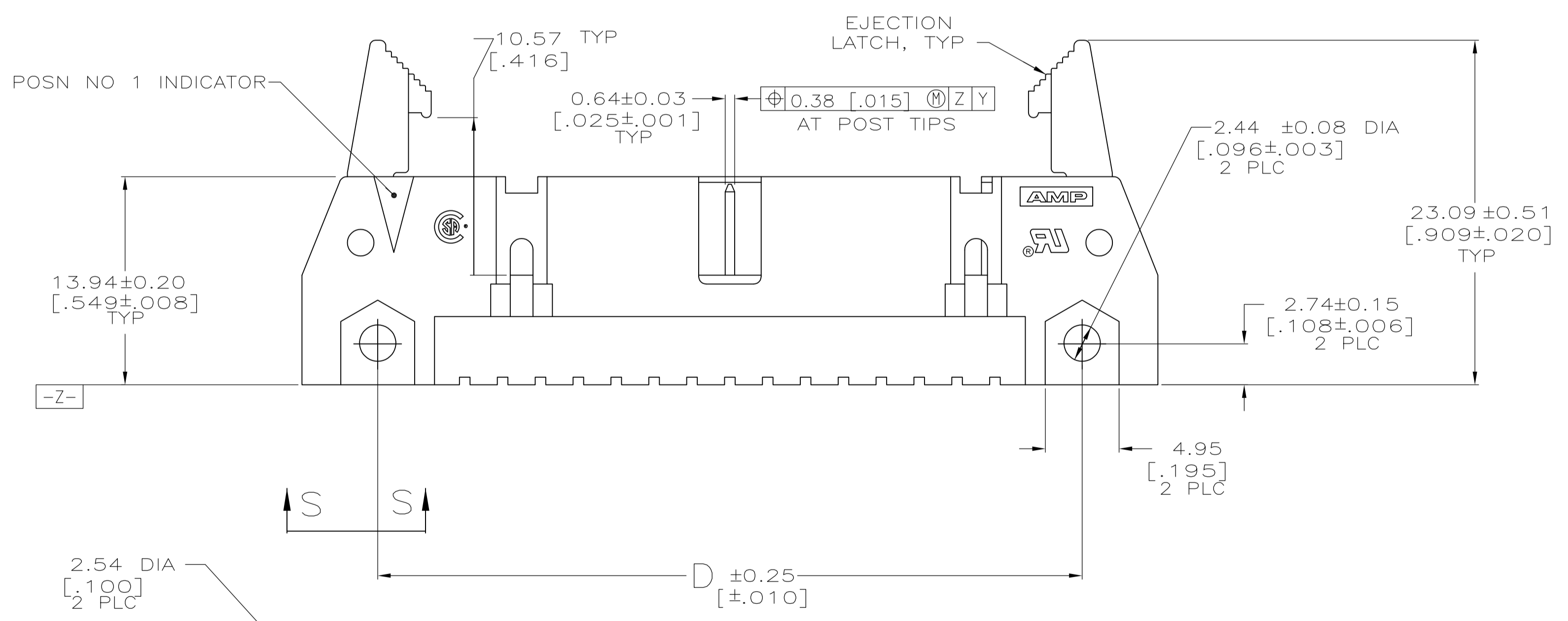
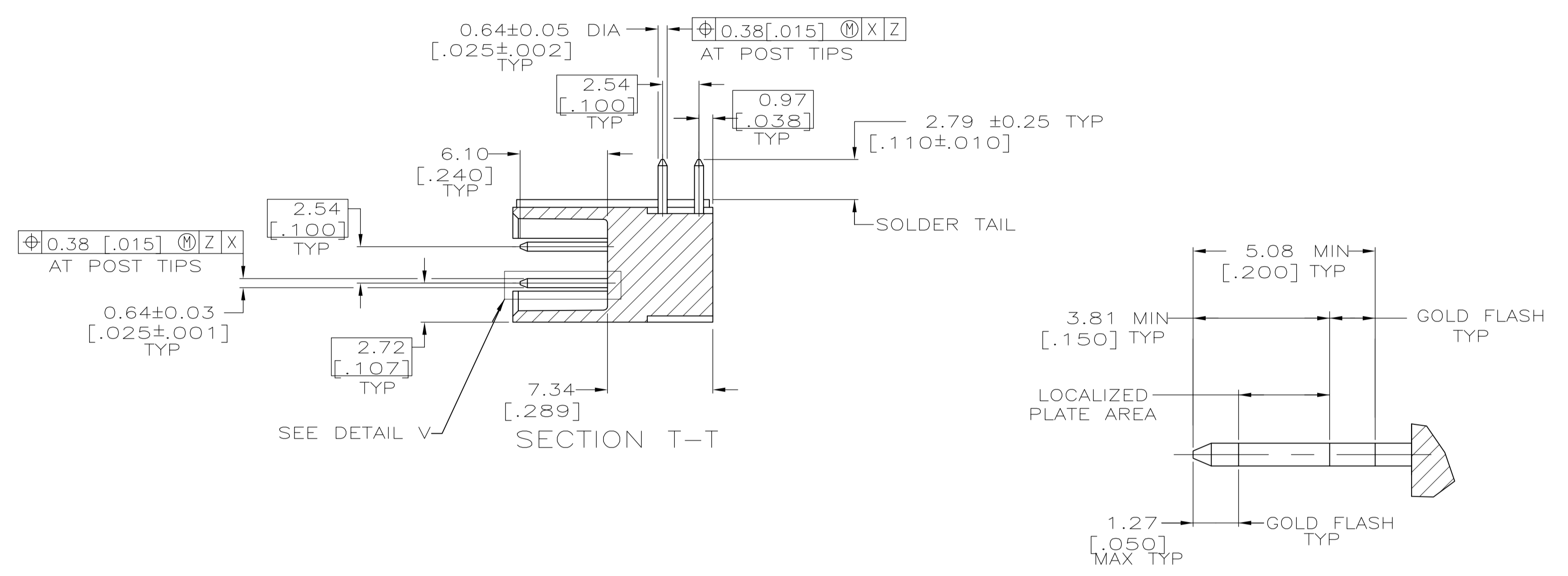
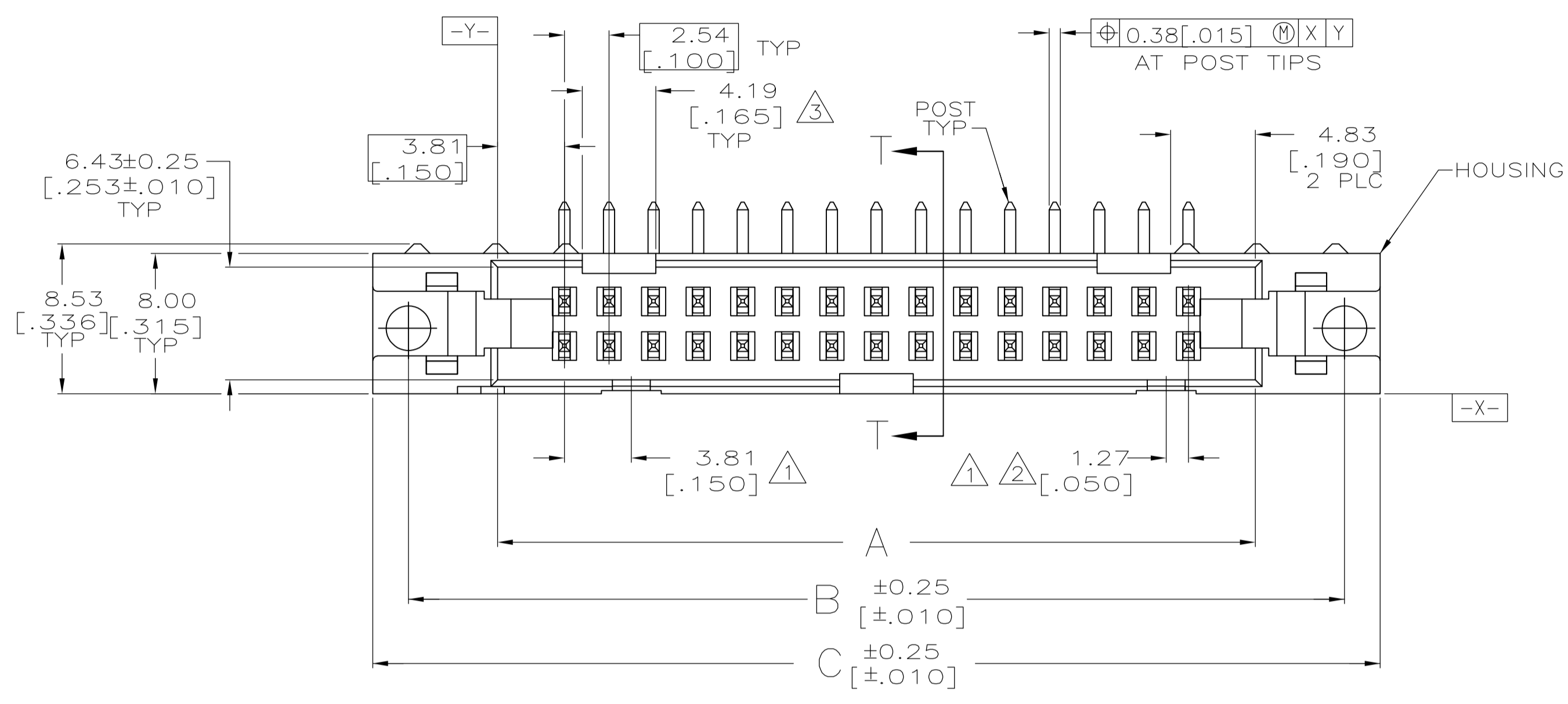

THIS DRAWING IS A CONTROLLED DOCUMENT.		DIN H.MOLL 4-23-90	Tyco Electronics Tyco Electronics Corporation Harrisburg, PA 17105-3608
DIMENSIONS: mm [INCHES]		CHK R.STONE 11-28-90	
TOLERANCES UNLESS OTHERWISE SPECIFIED:		APVD -	NAME
0 PLC ± -	1 PLC ± -	PRODUCT SPEC 108-40018	HEADER ASSY, UNIVERSAL, AMP-LATCH
2 PLC ± ± 0.13[.005]	3 PLC ± ± -	APPLICATION SPEC	
4 PLC ± ± -	ANGLES ± ± -	SIZE A1	CAGE CODE 00779
MATERIAL SEE SHEET 2	FINISH SEE SHEET 2	WEIGHT -	DRAWING NO 499913
		CUSTOMER DRAWING	RESTRICTED TO -
		SCALE 4:1	SHEET 1 OF 2
			REV H

- △ COORDINATE DIMENSION APPLIES FROM BASIC LOCATION.
- △ 10 AND 14 POSITION SIZES CONTAIN ONLY ONE SLOT FOR SNAP-IN POLARIZER (MILITARY POLARIZATION) LOCATED AS SHOWN.
- △ 10 POSITION SIZES CONTAIN ONLY ONE SLOT FOR DUAL POLARIZATION, LOCATED AS SHOWN.
- 4. RECOMMENDED PRINTED CIRCUIT BOARD THICKNESS IS 1.57 [.062].
- △ DISTANCE REQUIRED BY EJECTION LATCHES IN THE OPEN POSITION.
- △ POSTS:
 GOLD FLASH OVER
 0.38μm [.000015] MIN PALLADIUM-NICKEL PLATE ON THE LOCALIZED PLATE AREA,
 2.54μm [.000100] MIN TIN-LEAD PLATE ON THE SOLDER-TAIL,
 1.27μm [.000050] MIN NICKEL UNDERPLATE ON THE ENTIRE POST.
 OR
 0.38μm [.000015] MIN GOLD PLATE ON THE LOCALIZED PLATE AREA,
 2.54μm [.000100] MIN TIN-LEAD PLATE ON THE SOLDER-TAIL,
 1.27μm [.000050] MIN NICKEL UNDERPLATE ON THE ENTIRE POST.
- △ MATERIAL:
 HOUSING: GLASS FILLED NYLON OR POLYESTER, 94V-0 RATED, BLACK.
 POSTS: BRASS.

OBSOLETE	53.34	65.02	65.02	75.18	71.12	60.96	44	1-499913-3
	[2.100]	[2.560]	[2.560]	[2.960]	[2.800]	[2.400]		
OBSOLETE	78.74	90.42	90.42	100.58	96.52	86.36	64	1-499913-2
	[3.100]	[3.560]	[3.560]	[3.960]	[3.800]	[3.400]		
	73.66	85.34	85.34	95.50	91.44	81.28	60	1-499913-1
	[2.900]	[3.360]	[3.360]	[3.760]	[3.600]	[3.200]		
	60.96	72.64	72.64	82.80	78.74	68.58	50	1-499913-0
	[2.400]	[2.860]	[2.860]	[3.260]	[3.100]	[2.700]		
	48.26	59.94	59.94	70.10	66.04	55.88	40	499913-9
	[1.900]	[2.360]	[2.360]	[2.760]	[2.600]	[2.200]		
	40.64	52.32	52.32	62.48	58.42	48.26	34	499913-8
	[1.600]	[2.060]	[2.060]	[2.460]	[2.300]	[1.900]		
	35.56	47.24	47.24	57.40	53.34	43.18	30	499913-7
	[1.400]	[1.860]	[1.860]	[2.260]	[2.100]	[1.700]		
	30.48	42.16	42.16	52.32	48.26	38.10	26	499913-6
	[1.200]	[1.660]	[1.660]	[2.060]	[1.900]	[1.500]		
	27.94	39.62	39.62	49.78	45.72	35.56	24	499913-5
	[1.100]	[1.560]	[1.560]	[1.960]	[1.800]	[1.400]		
	22.86	34.54	34.54	44.70	40.64	30.48	20	499913-4
	[.900]	[1.360]	[1.360]	[1.760]	[1.600]	[1.200]		
	17.78	29.46	29.46	39.62	35.56	25.40	16	499913-3
	[.700]	[1.160]	[1.160]	[1.560]	[1.400]	[1.000]		
	15.24	26.92	26.92	37.08	33.02	22.86	14	499913-2
	[.600]	[1.060]	[1.060]	[1.460]	[1.300]	[.900]		
	10.16	21.84	21.84	32.00	27.94	17.78	10	499913-1
	[.400]	[.860]	[.860]	[1.260]	[1.100]	[.700]		
	F	E	D	C	B	A	NO OF POSN	PART NUMBER

THIS DRAWING IS A CONTROLLED DOCUMENT.		DIN 4-23-90	Tyco Electronics Corporation	
DIMENSIONS: mm [INCHES]		CHK R. STONE 11-28-90	Harrisburg, PA 17105-3608	
TOLERANCES UNLESS OTHERWISE SPECIFIED:		APVD	NAME	
0 PLC ± -	1 PLC ± -	PRODUCT SPEC 108-40018		
2 PLC ± 0.13[.005]	3 PLC ± -	APPLICATION SPEC		
4 PLC ± -	ANGLES ± -	SIZE	CAGE CODE	DRAWING NO
MATERIAL		WEIGHT	A1 00779	499913
FINISH		CUSTOMER DRAWING		
SCALE 4:1		SHEET 2 OF 2		